

# CMSC414 Computer and Network Security

Introduction to Networking

Yizheng Chen | University of Maryland  
[surrealyz.github.io](https://surrealyz.github.io)

Apr 14, 2026

Credits: original slides from instructors and staff from CS161 at UC Berkeley. Blue slides will not be tested.

# Announcement

- Project 4 released, deadline extended to Monday April 27
- If you haven't, pls sign up groups on ELMS, email me!

# Agenda

- Internet: A global network of computers
- OSI model: A layered model of protocols
  - Stands for “Open Systems Interconnection model”

# What's the Internet?

- **Network:** A set of connected machines that can communicate with each other
  - Over a **protocol**, a set of rules for communication
- **Internet:** A global network of computers
  - Web
  - SSH
  - Internet of Things: TV, Watch, Game Consoles, ...

# Protocols

- A **protocol** is an agreement on how to communicate that specifies syntax and semantics
  - *Syntax*: How a communication is specified and structured (format, order of messages)
  - *Semantics*: What a communication means (actions taken when sending/receiving messages)

# SSL Handshake (RSA)

## Handshake

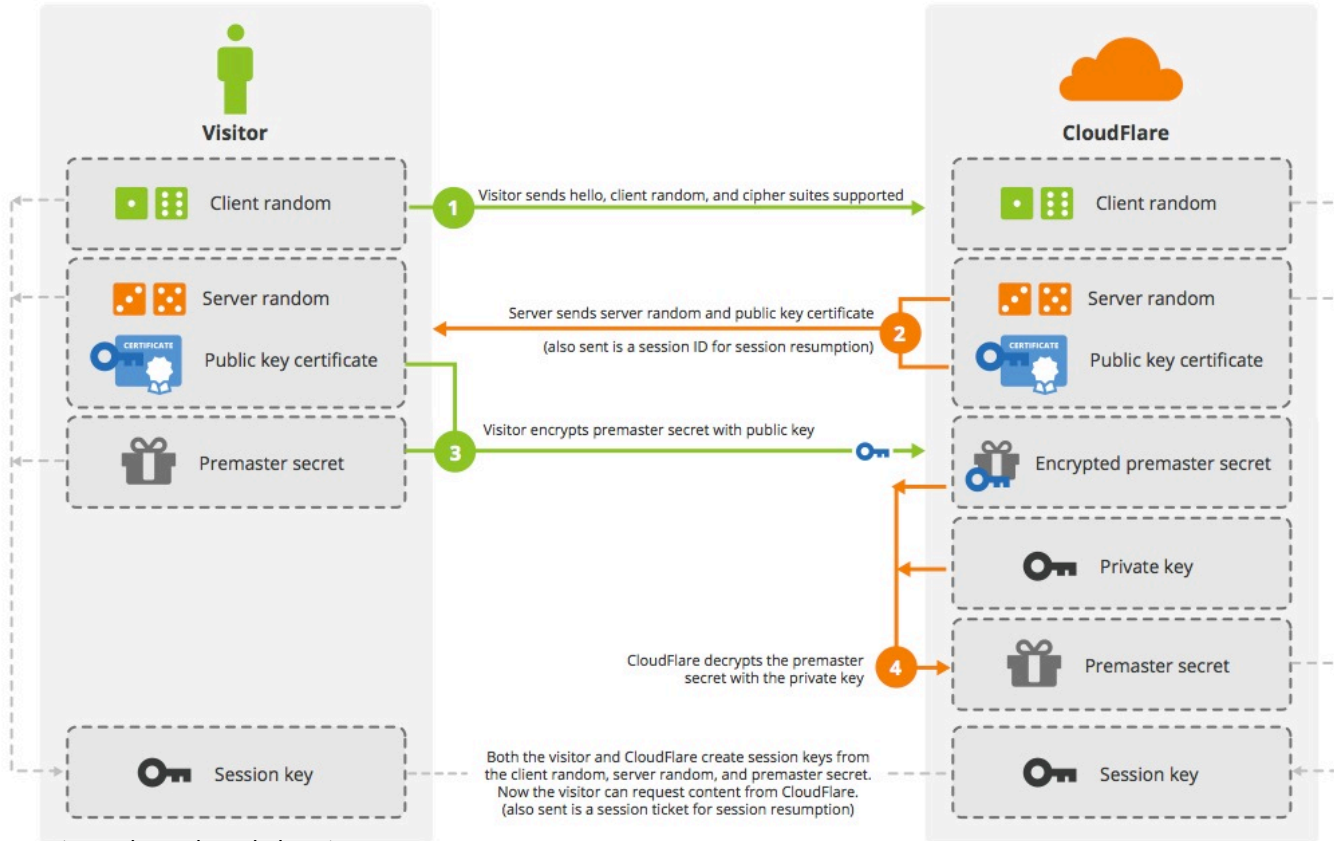

(Credit: CloudFlare)

# SSL Handshake (RSA)

Handshake



(Credit: CloudFlare)

# SSL Handshake (RSA)

Handshake

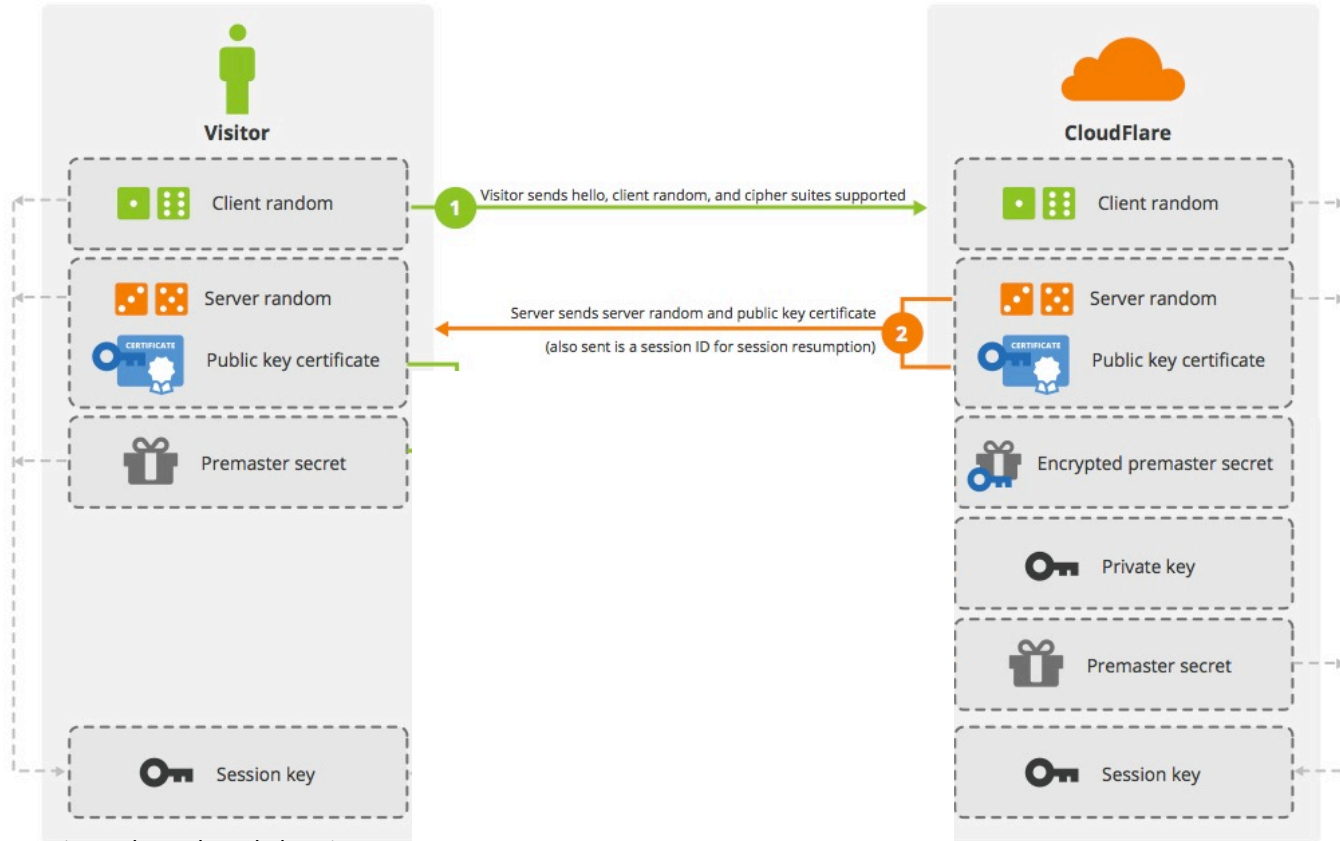

(Credit: CloudFlare)

# SSL Handshake (RSA)

Handshake

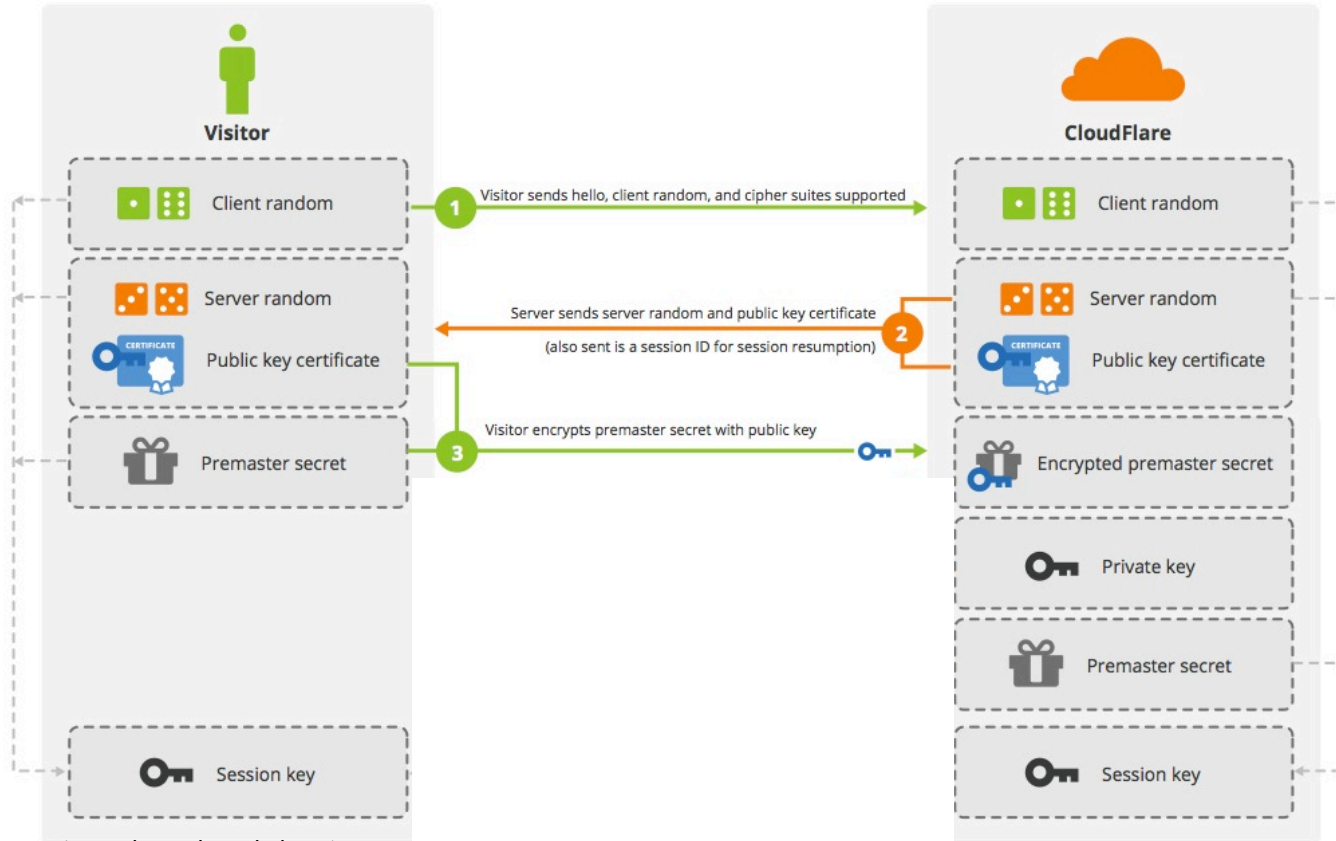

(Credit: CloudFlare)

# SSL Handshake (RSA)

Handshake

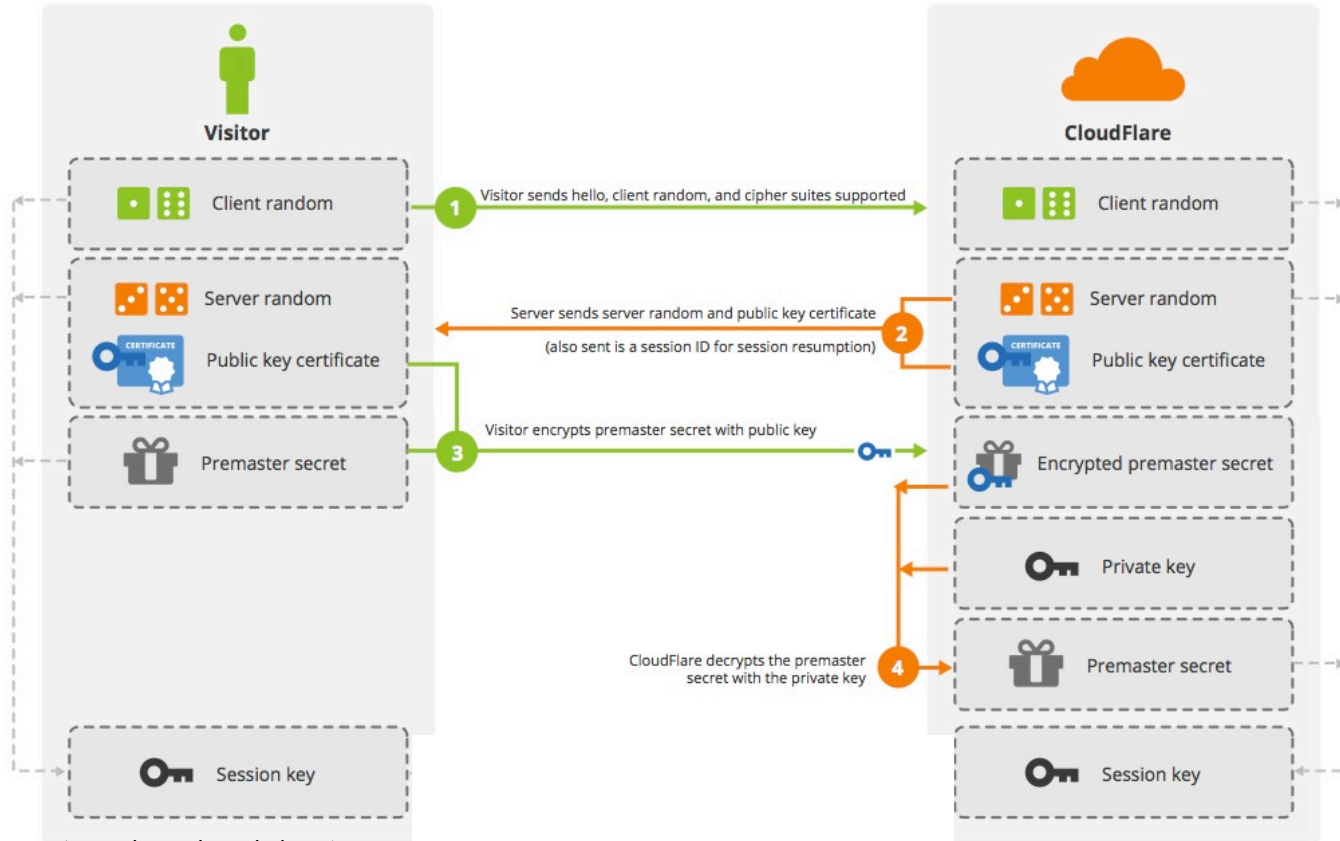

(Credit: CloudFlare)

# SSL Handshake (RSA)

## Handshake

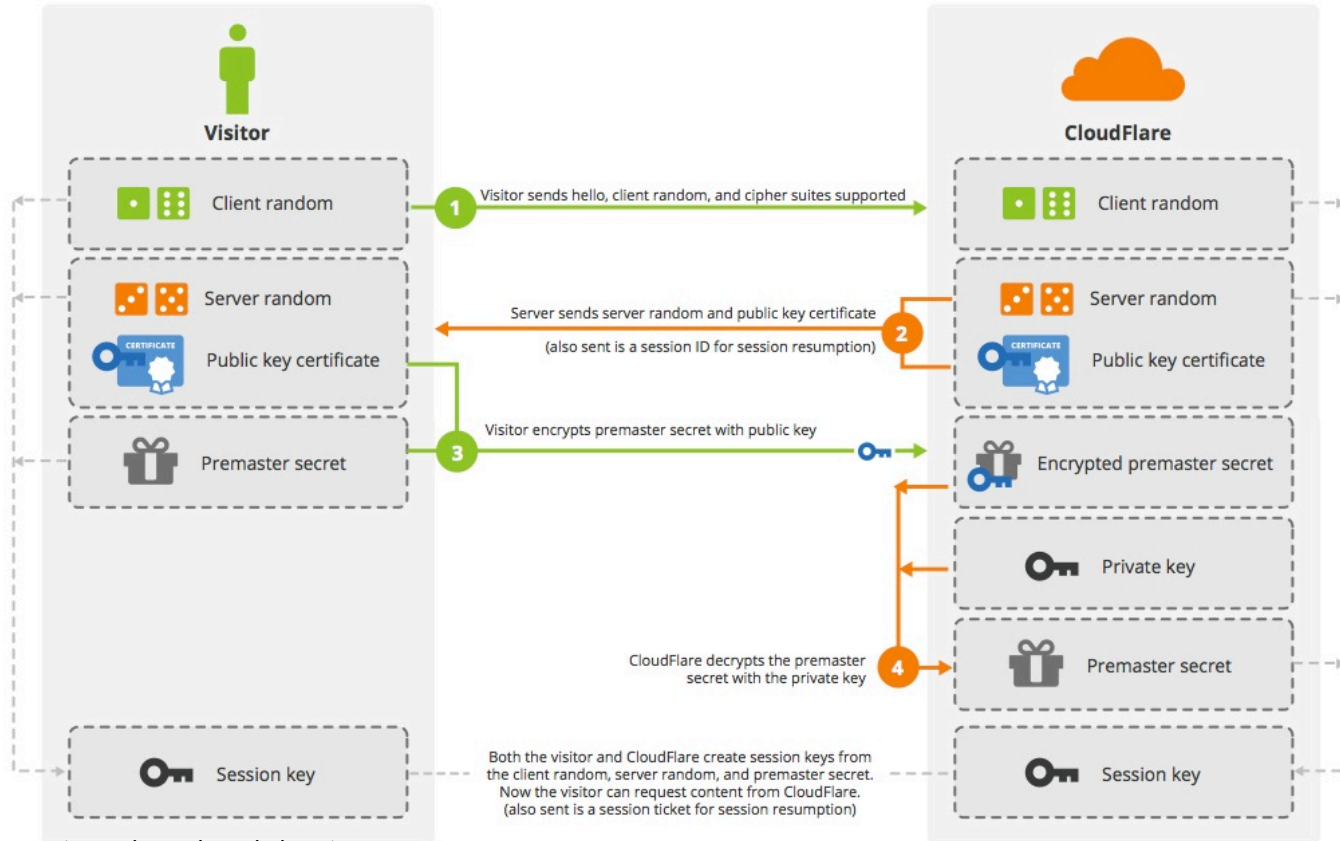

(Credit: CloudFlare)

# Internet Analogy: Mail

# What's the goal of the Internet?

- Move data from one location to another
- Analogy: I write a message on a piece of paper. How do I send this message to you?
- Solution: Postal system

# Building block 1: Something That Moves Data

- The Internet is built on technology that moves bits across space
- Voltages on wires, wireless technology, radio waves, etc.
- Packets could be lost

# Building block 2: Talking to the Apartment Complex

- Using building block 1, we can link up people within a local apartment complex
- Forms a local area network (LAN)

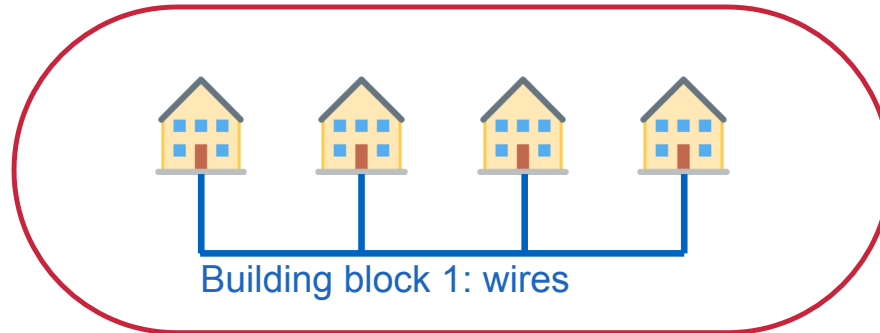

Building block 2: local network

# Building block 3: Post offices

- A post office connects two or more apartment complexes
- Forms a wide area network

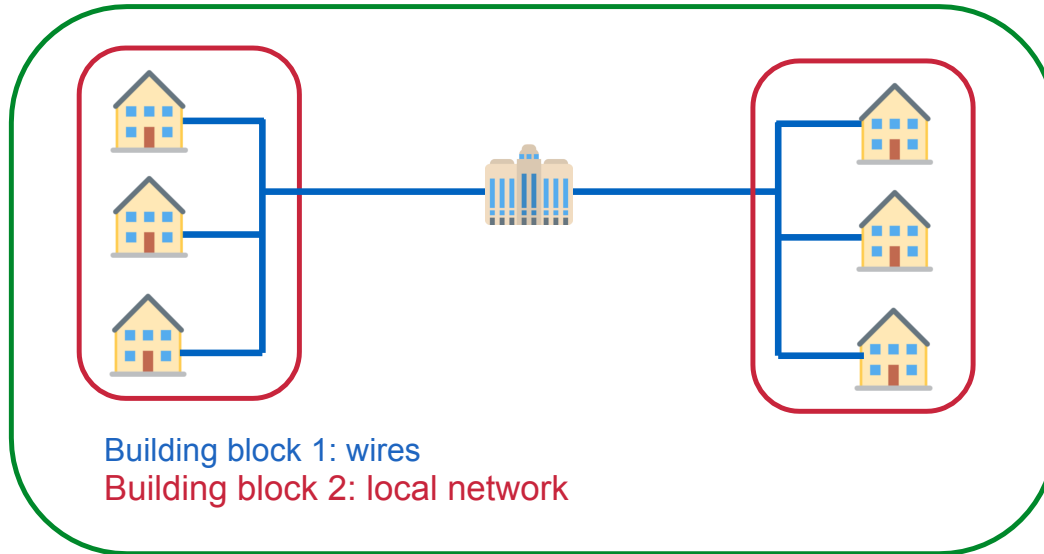

Building block 1: wires

Building block 2: local network

Building block 3: wide area network

# Building block 3: The Internet

- Connect the entire world using post offices
- Messages may pass through multiple post offices before reaching destination

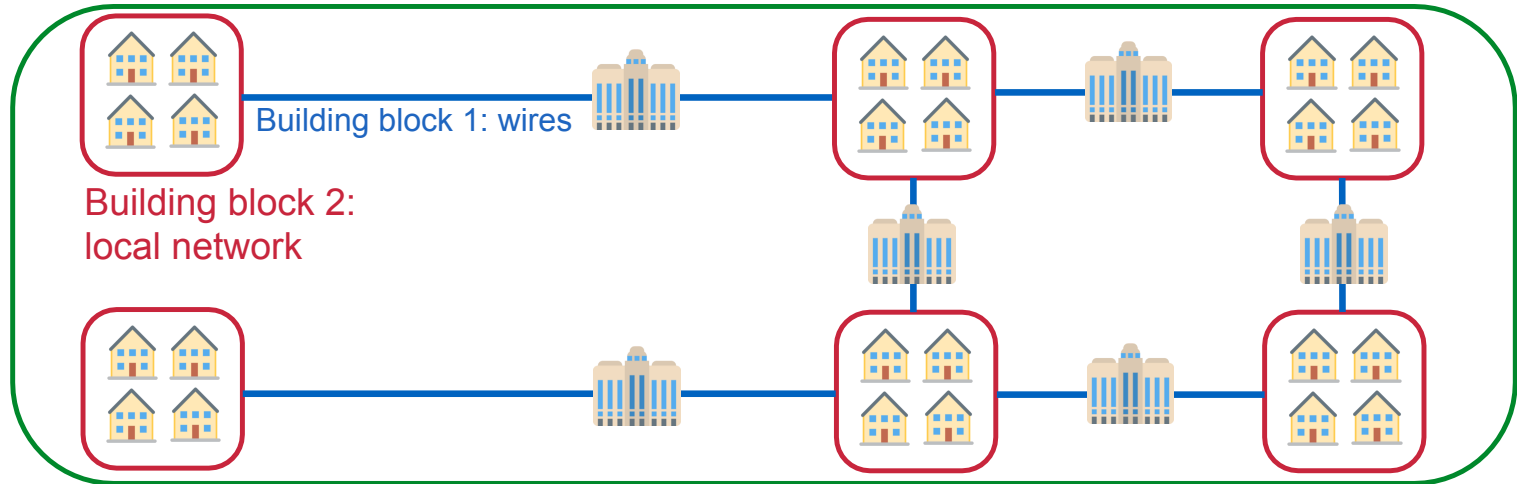

Building block 3: the Internet

# Layers of abstraction

Layer 3: Connect many local networks to form a global network

Layer 2: Create links in a local area

Layer 1: Move bits across space

- A change in layer 1 implementation (wireless instead of wires) doesn't affect the other layers
- A change in layer 2 protocols doesn't affect the other layers

# Layering: The OSI Model

# Layering

- Internet design is partitioned into various layers. Each layer...
  - Has a protocol
  - Relies on services provided by the layer below it
  - Provides services to the layer above it
- Analogous to the structure of an application and the “services” that each layer relies on and provides

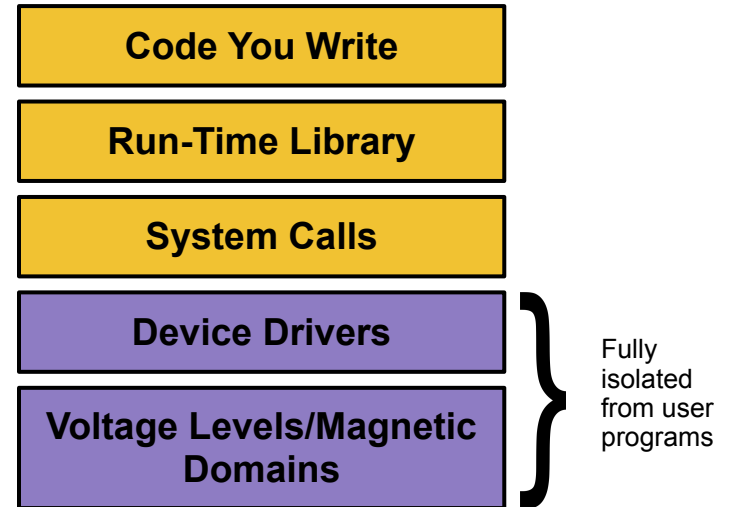

# OSI Model

- **OSI model:** Open Systems Interconnection model, a layered model of Internet communication
  - Originally divided into 7 layers
    - But layers 5 and 6 aren't used in the real world, so we ignore them
- Same reliance upon abstraction
  - A layer can be implemented in different ways without affecting other layers
  - A layer's protocol can be substituted with another protocol without affecting other layers

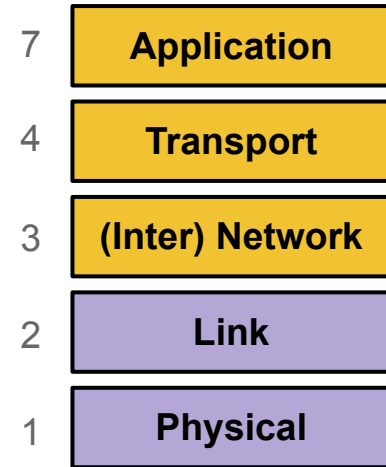

# Layer 1: Physical Layer

- **Provides:** Sending bits from one device to another
  - Encodes bits to send them over a physical link
    - Patterns of voltage levels
    - Photon intensities
    - RF modulation
- **Examples**
  - Wi-Fi radios (IEEE 802.11)
  - Ethernet voltages (IEEE 802.3)

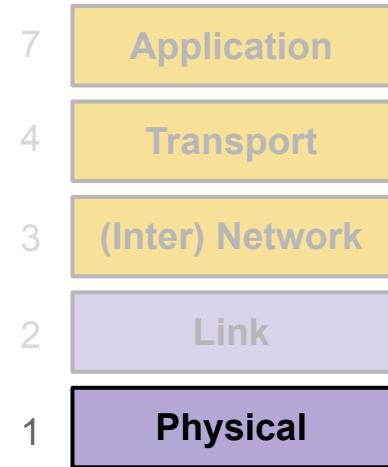

# Layer 1: Physical Layer

Physical layer: “How do I transmit this sequence of 0’s and 1’s from A to B?”

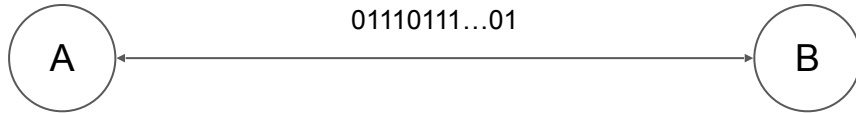

Next: How do we talk to more than one device?

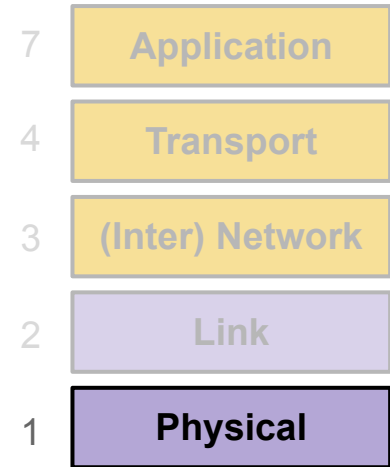

# Layer 2: Link Layer

- **Provides:** Sending frames directly from one device to another
  - **Relies upon:** Sending bits from one device to another
  - Encodes messages into groups of bits called “frames”
- **Examples**
  - Ethernet frames (IEEE 802.3)

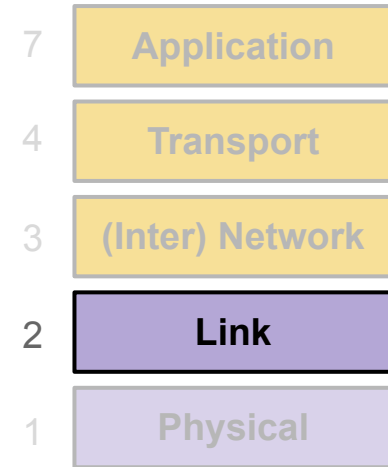

# Layer 2: Link Layer

- **Local area network (LAN):** A set of computers on a shared network that can directly address one another
  - Consists of multiple physical links
- Frames must consist of at least 3 things:
  - Source (“Who is this message coming from?”)
  - Destination (“Who is this message going to?”)
  - Data (“What does this message say?”)

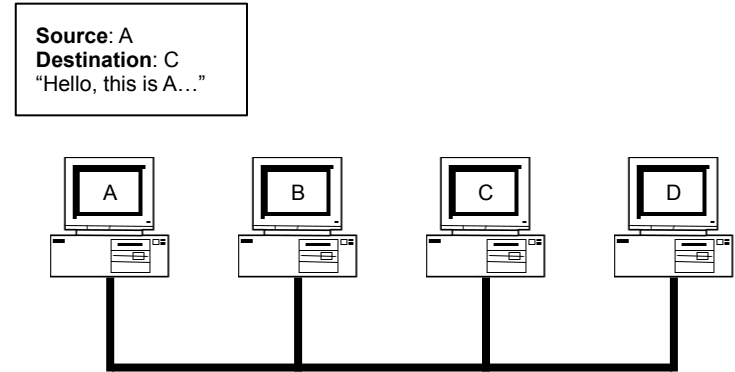

# Layer 2: Link Layer

- In reality, computers aren't all connected to the same wire
  - Instead, local networks are a set of point-to-point links
- However, Layer 2 still allows direct addressing between any two devices
  - Enabled by transmitting a frame across multiple physical links until it reaches its destination

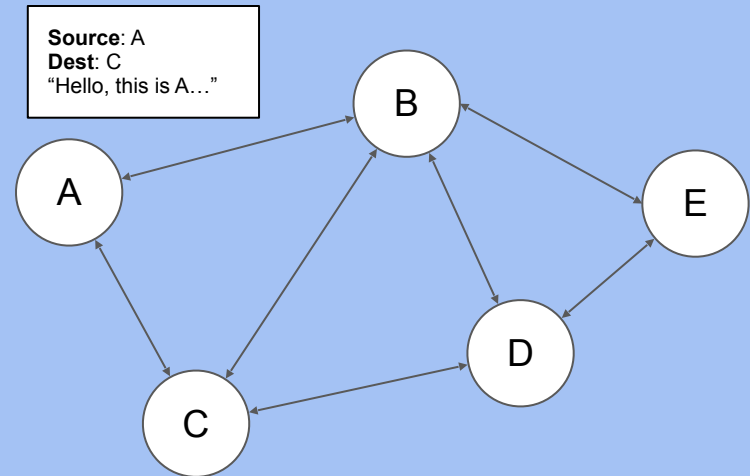

# Ethernet and MAC Addresses

- **Ethernet:** A common layer 2 protocol that most endpoint devices use
- **MAC address:** A 6-byte address that identifies a piece of network equipment (e.g. your phone's Wi-Fi antenna)
  - Typically represented as 6 hex bytes: **13:37:ca:fe:f0:0d**
  - The first 3 bytes are assigned to manufacturers (i.e. who made the equipment)
    - This is useful in identifying a device
  - The last 3 bytes are device-specific

# Layer 2: Link Layer

Link layer: “How do I transmit this frame from A to C, making sure that no one else thinks the message is for them?”

Source: A  
Dest: C  
“Hello, this is A...”

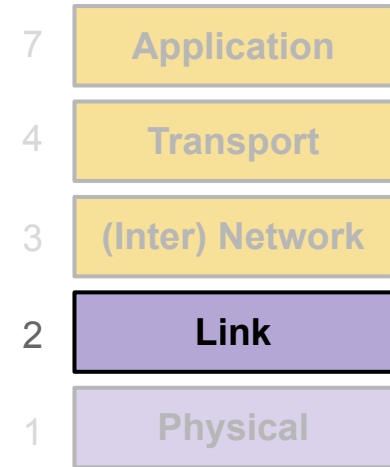
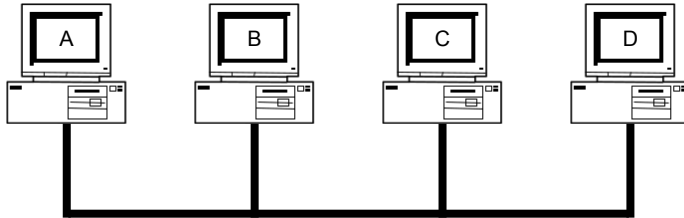

Next: How do we address every device in existence?

# Layer 3: Network Layer

- **Provides:** Sending packets from any device to any other device
  - **Relies upon:** Sending frames directly from one device to another
  - Encodes messages into groups of bits called “packets”
  - Bridges multiple LANs to provide global addressing
- **Examples**
  - Internet Protocol (IP)

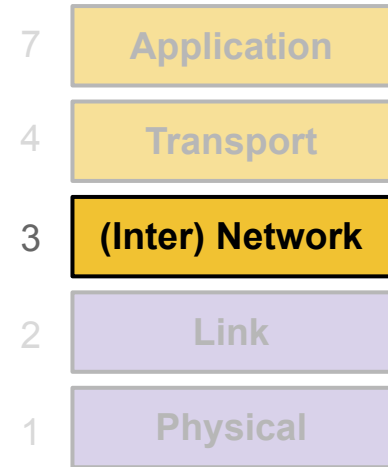

# Layer 3: Network Layer

- Recall the ideal layer 2 model: All devices can directly address all other devices
  - This would not scale to the size of the Internet!
- Instead, allow packets to be **routed** across different devices to reach the destination
  - Each hop is allowed to use its own physical and link layers!

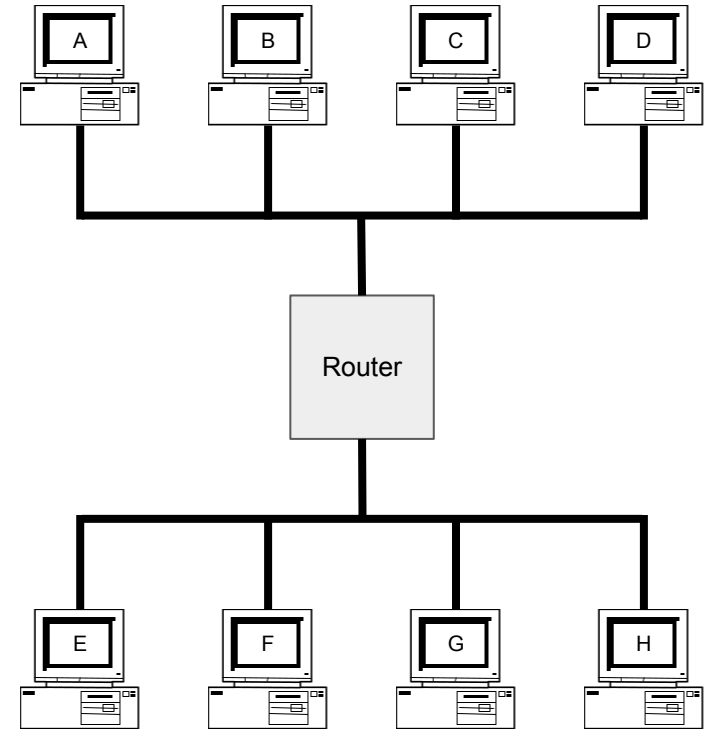

# Layer 3: Network Layer

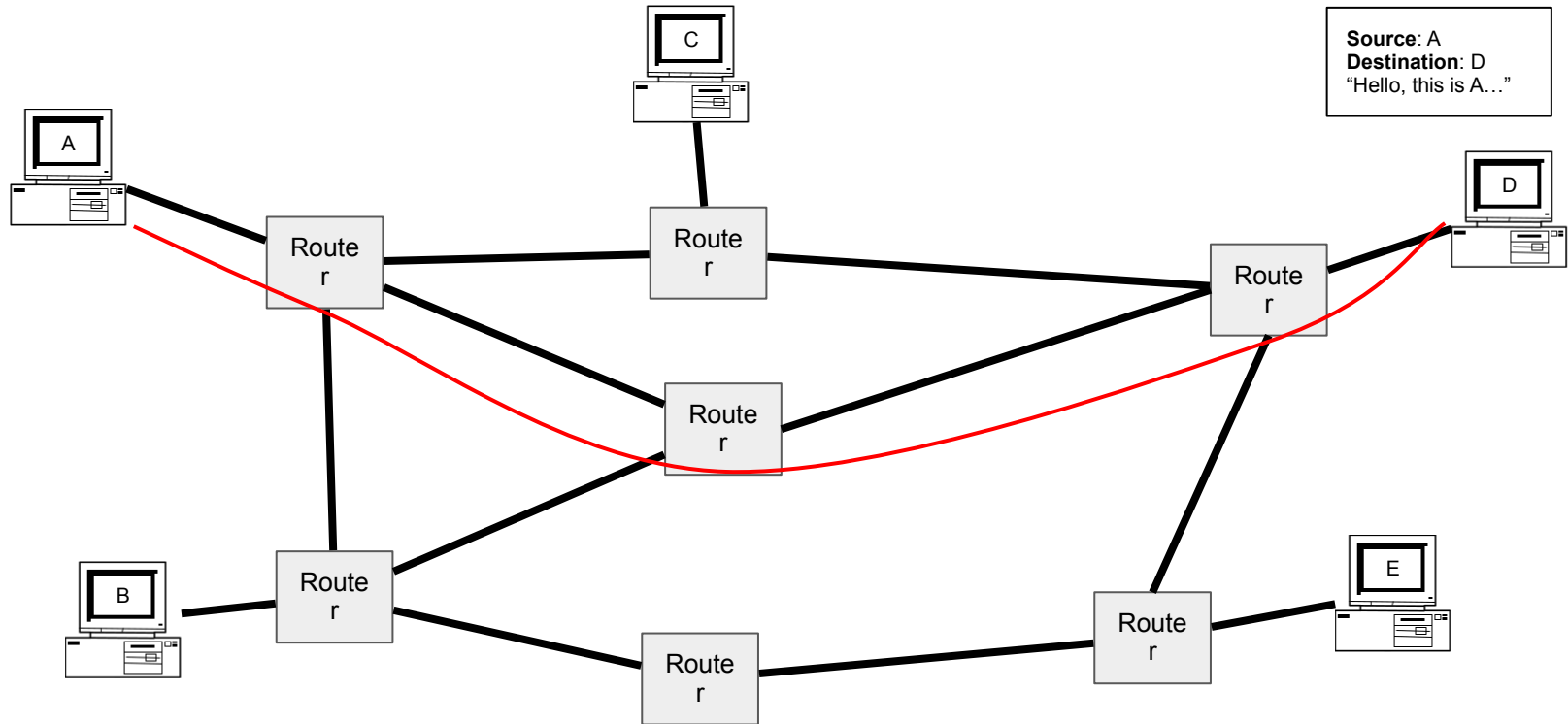

# Layer 3: Network Layer

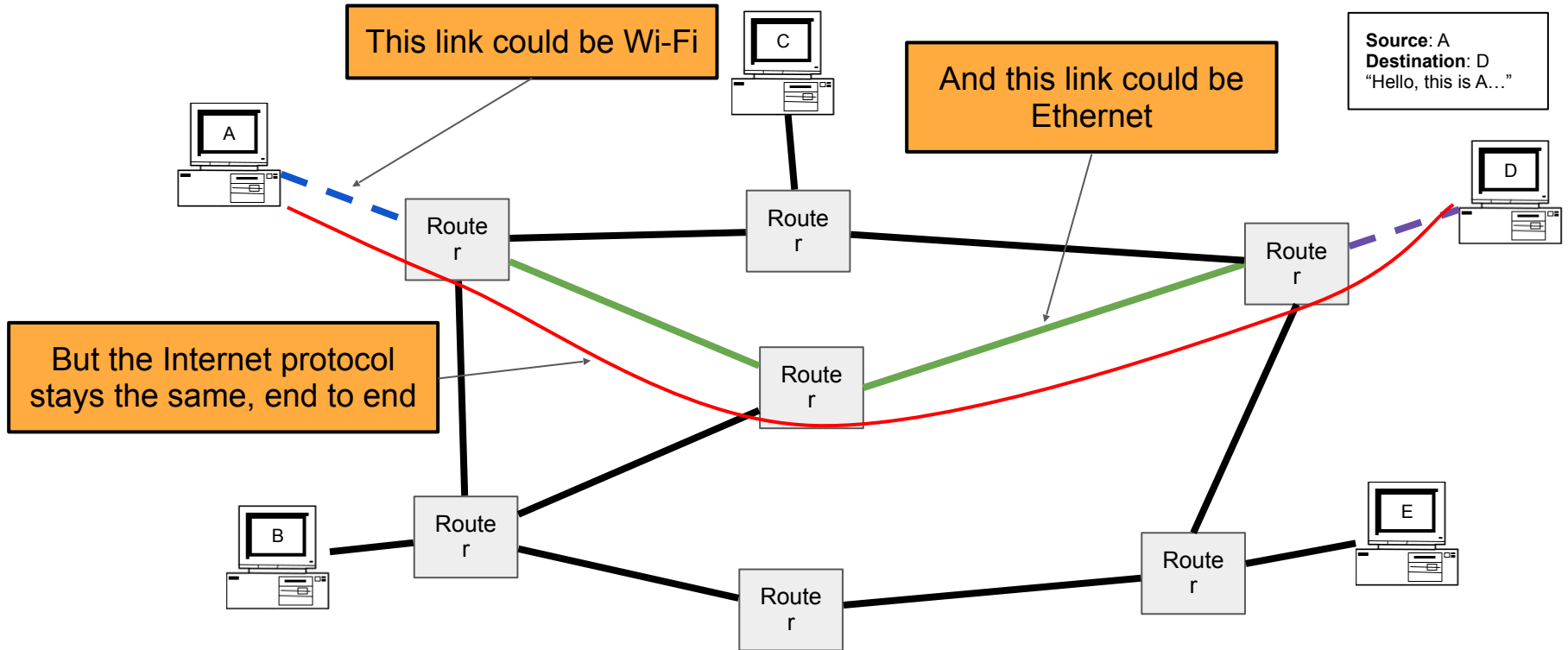

# Layer 3: Network Layer

- Packets must consist of at least 3 things:
  - Source (“Who is this message coming from?”)
  - Destination (“Who is this message going to?”)
  - Data (“What does this message say?”)
  - Similar to frames (layer 2)
- Packets may be fragmented into smaller packets
  - Different links might support different maximum packet sizes
  - Up to the recipient to reassemble fragments into the original packet
- Each router forwards a given packet to the next hop
  - We will cover how a router knows how to forward—and attacks on it—in the future
- Packets are not guaranteed to take a given route
  - Two packets with the same source and destination may take different routes

# Internet Protocol (IP)

- **Internet Protocol (IP):** The universal layer-3 protocol that all devices use to transmit data over the Internet
- **IP address:** An address that identifies a device on the Internet
  - IPv4 is 32 bits, typically written as 4 decimal octets, e.g. **35.163.72.93**
  - IPv6 is 128 bits, typically written as 8 groups of 2 hex bytes: **2607:f140:8801::1:23**
    - If digits or groups are missing, fill with 0's, so  
**2607:f140:8801:0000:0000:0000:0001:0023**
  - Globally unique from any single perspective
    - For now, you can think of them as just being globally unique
  - IP addresses help nodes make decisions on where to forward the packet

# Reliability

- **Reliability** ensures that packets are received correctly or, if random errors occur, not at all
  - This is implemented with a checksum
  - However, there is no cryptographic MAC, so there are no guarantees if an attacker modifies packets
- IP is *unreliable* and only provides a **best effort** delivery service, which means:
  - Packets may be lost (“dropped”)
  - Packets may be corrupted
  - Packets may be delivered out of order
- It is up to higher level protocols to ensure that the connection is reliable

# Layer 3: Network Layer

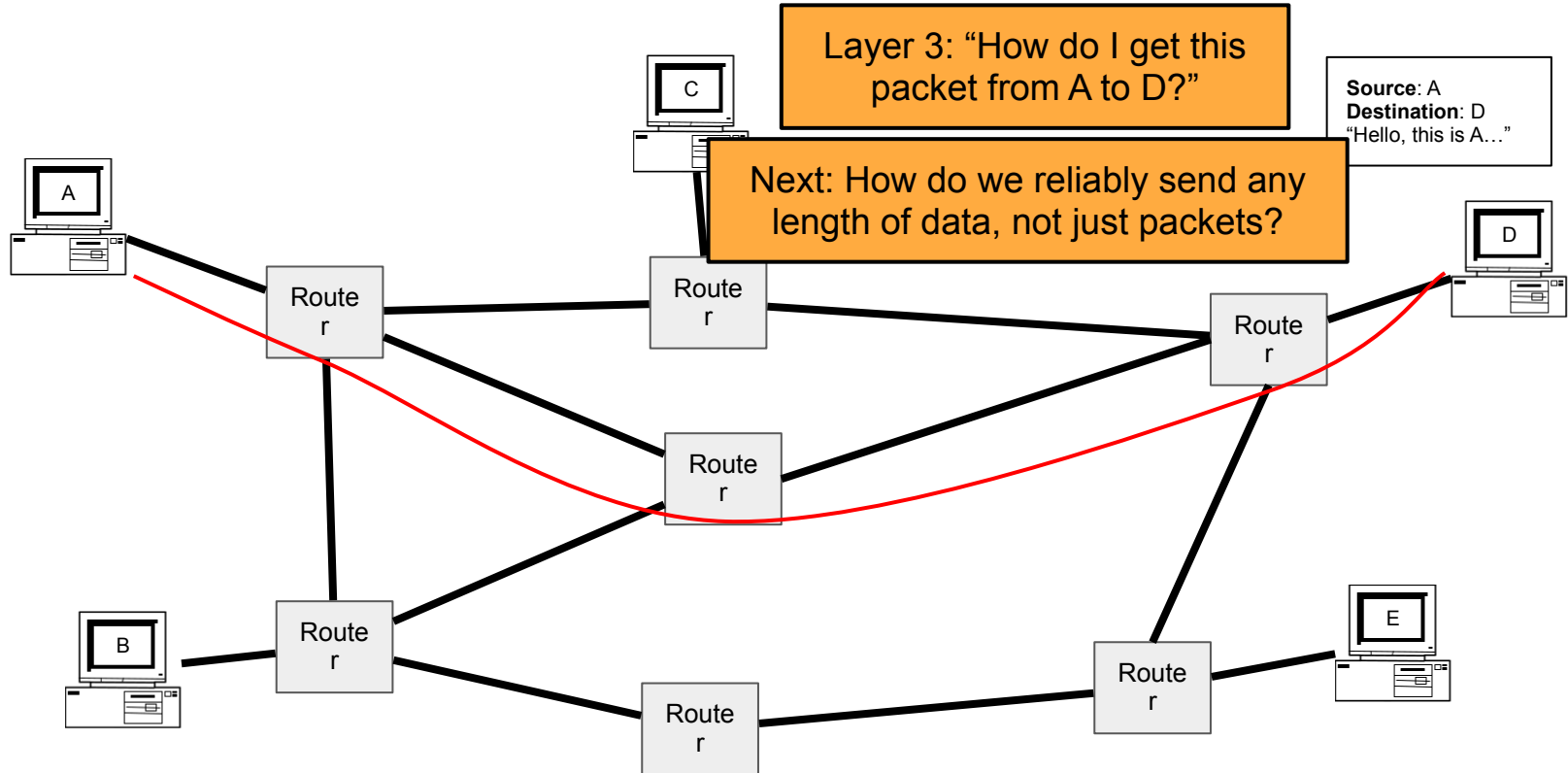

# Layer 4: Transport Layer

- **Provides:** Transportation of variable-length data from any point to any other point
  - **Relies upon:** Sending packets from any device to any other device
  - Builds abstractions that are useful to applications on top of layer 3 packets
- Useful abstractions
  - **Reliability:** Transmit data reliably, in order
  - **Ports:** Provide multiple “addresses” per real IP address
- Examples
  - **TCP:** Provides reliability and ports
  - **UDP:** Provides ports, but no reliability

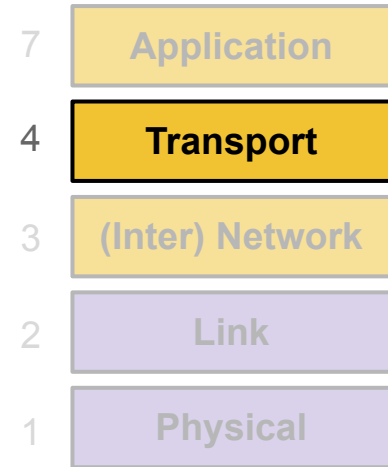

# Layer 4: Transport Layer

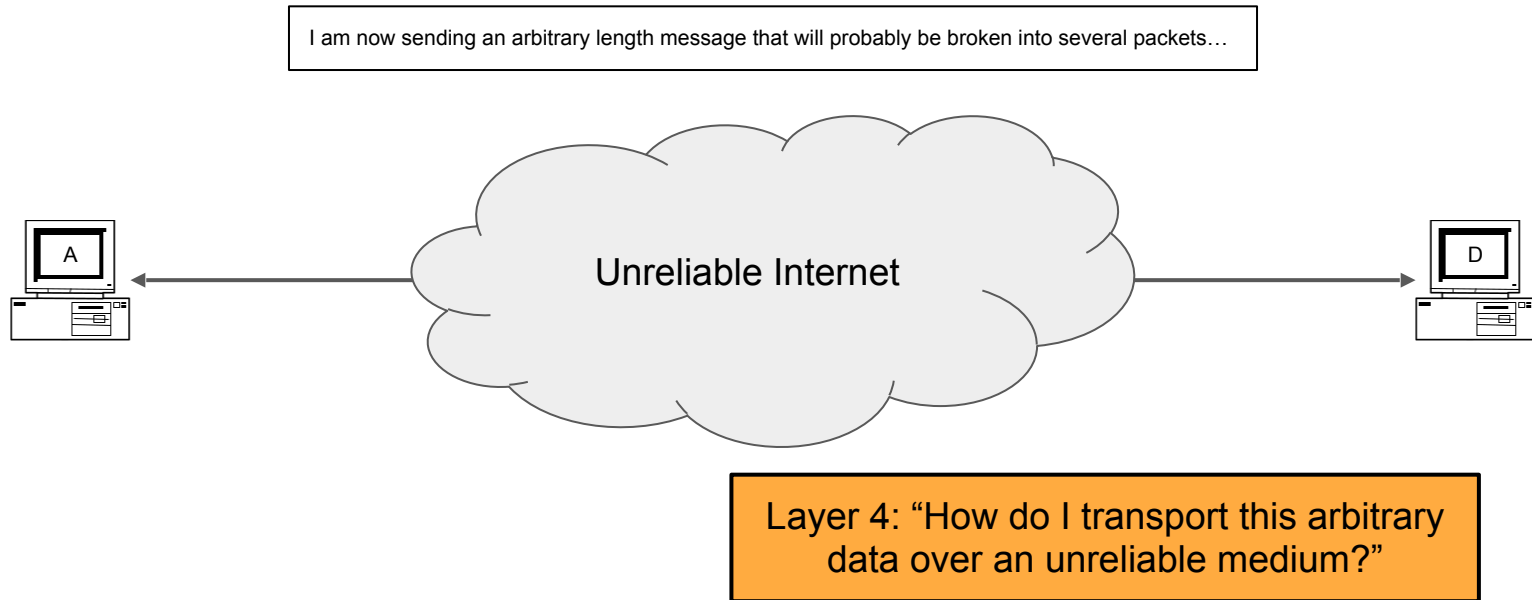

# Layer 7: Application Layer

- **Provides:** Applications and services to users!
  - **Relies upon:** Transportation of variable-length data from any point to any other point
- Every online application is Layer 7
  - Web browsing
  - Online video games
  - Messaging services
  - Video calls (Zoom)

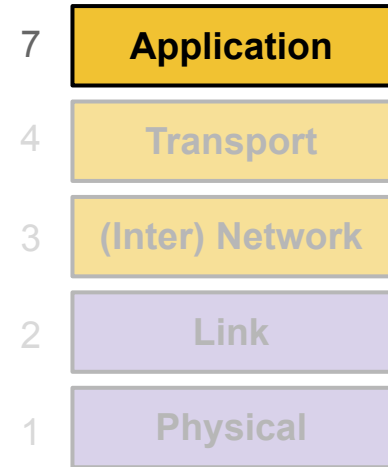

# Headers

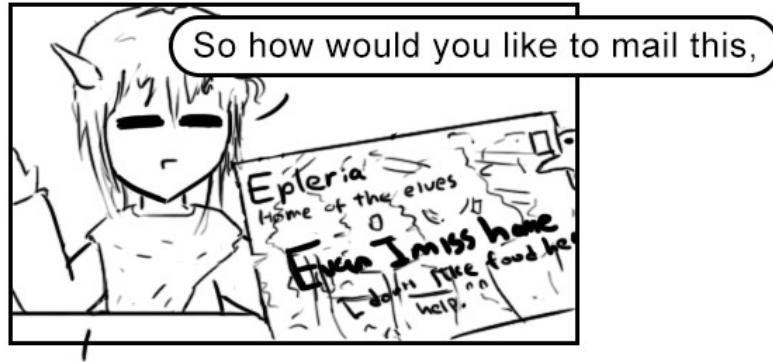

# Example: Sending Mail

Alice



I am  
hungry.

Bob



# Example: Sending Mail

Alice



Send to: Bob

I am hungry.

Bob



# Example: Sending Mail

Alice



Mail to: 123 Bob

Send to: Bob

I am  
hungry.

Bob



# Example: Sending Mail

Alice



Bob



Mail to: 123 Bob  
St.  
Send to: Bob  
I am  
hungry.

# Example: Sending Mail

Alice



Bob



Send to: Bob  
I am hungry.



# Example: Sending Mail

Alice



Bob

I am hungry.



# Example: Sending Mail

Alice



**Relies upon:**  
Sending messages to people



**Provides:** Sending messages to people  
**Relies upon:** Sending messages to addresses



**Provides:** Sending messages to addresses

Each layer communicates with each other, relying on abstractions below them!

Bob



# Layers of Abstraction and Headers

- As you move to lower layers, you wrap additional headers around the message
- As you move to higher layers, you peel off headers around the message

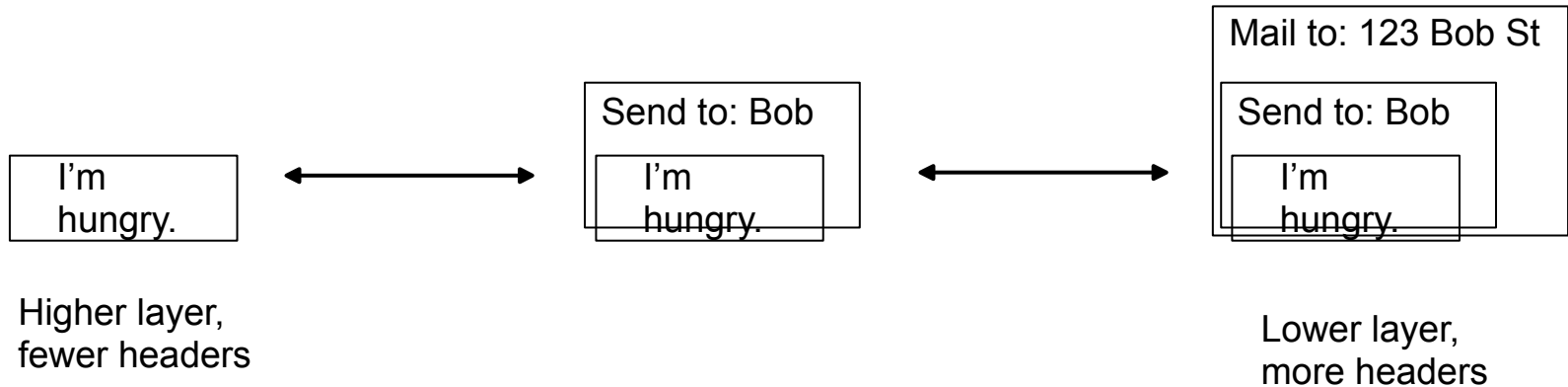

# Layers of Abstraction and Headers

- As you move to lower layers, you wrap additional headers around the message
- As you move to higher layers, you peel off headers around the message
- When sending a message we go from the highest to the lowest layer
- When receiving a message we go from the lowest to highest layer

# Layer 2 Header

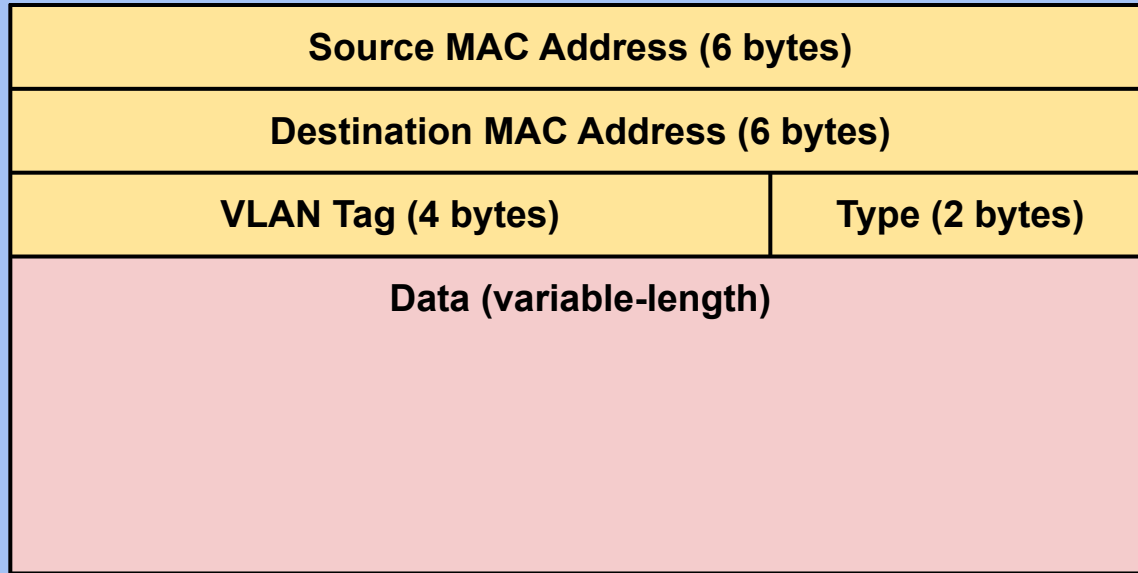

Ethernet and MAC address headers

# Layer 3 Header

Version (4 bits)	Header Length (4 bits)	Type of Service (6 bits)	ECN (2 bits)	Total Length (16 bits)	
Identification (16 bits)			Flags (3 bits)	Fragment Offset (13 bits)	
Time to Live (8 bits)	Protocol (8 bits)		Header Checksum (16 bits)		
Source Address (32 bits)					
Destination Address (32 bits)					
Options (variable length)					
Data (variable length)					

IPv4 header

# Example: HTTP Request

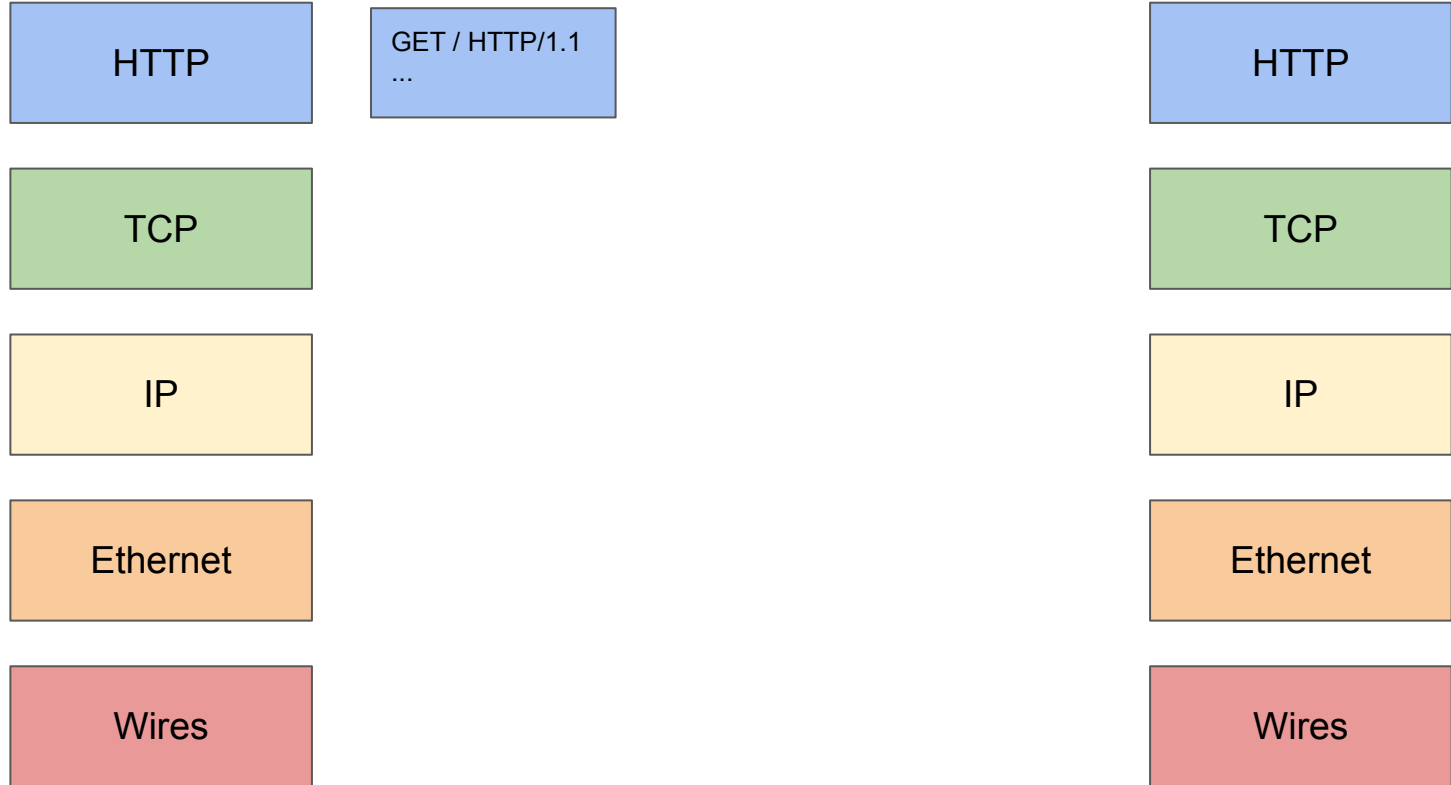

# Example: HTTP Request

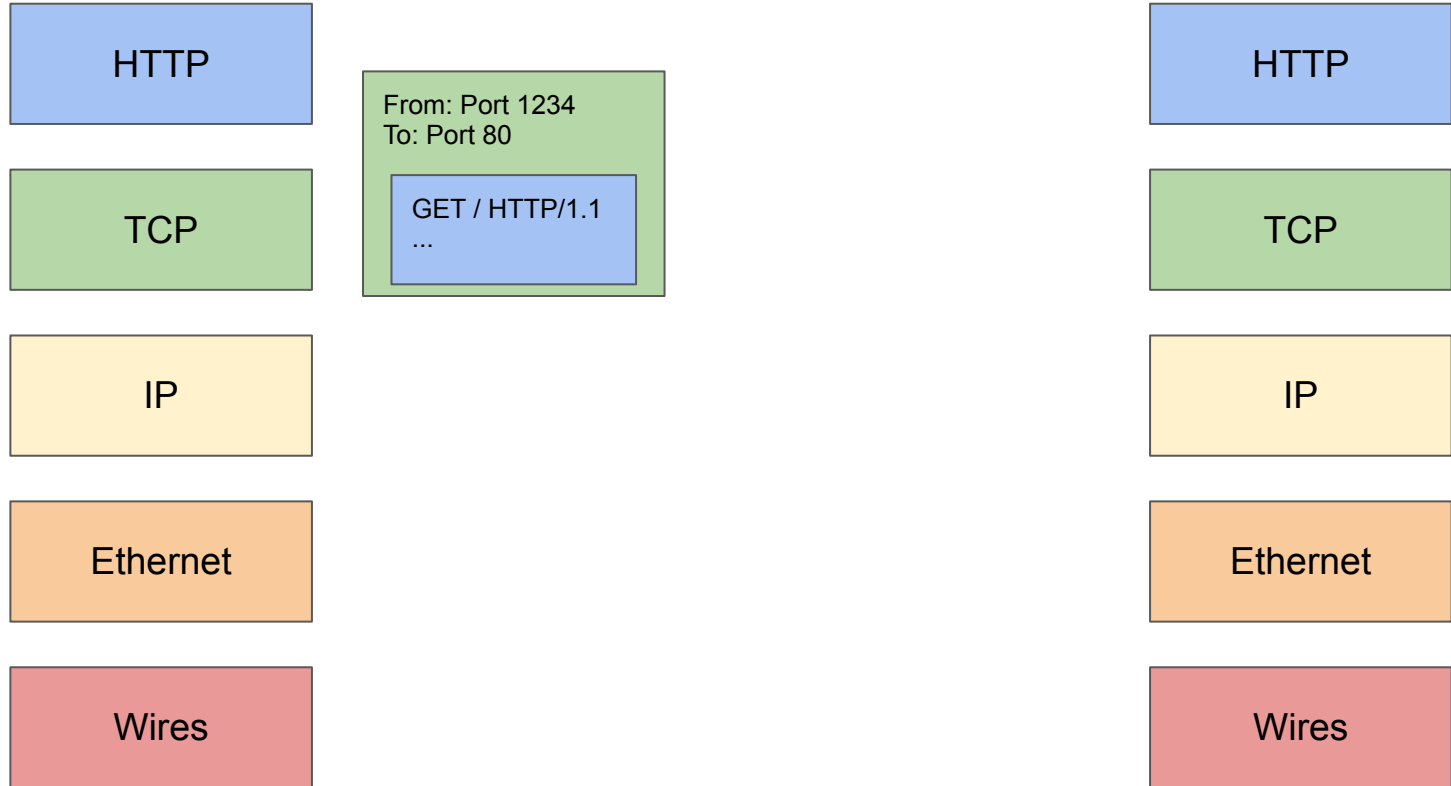

# Example: HTTP Request

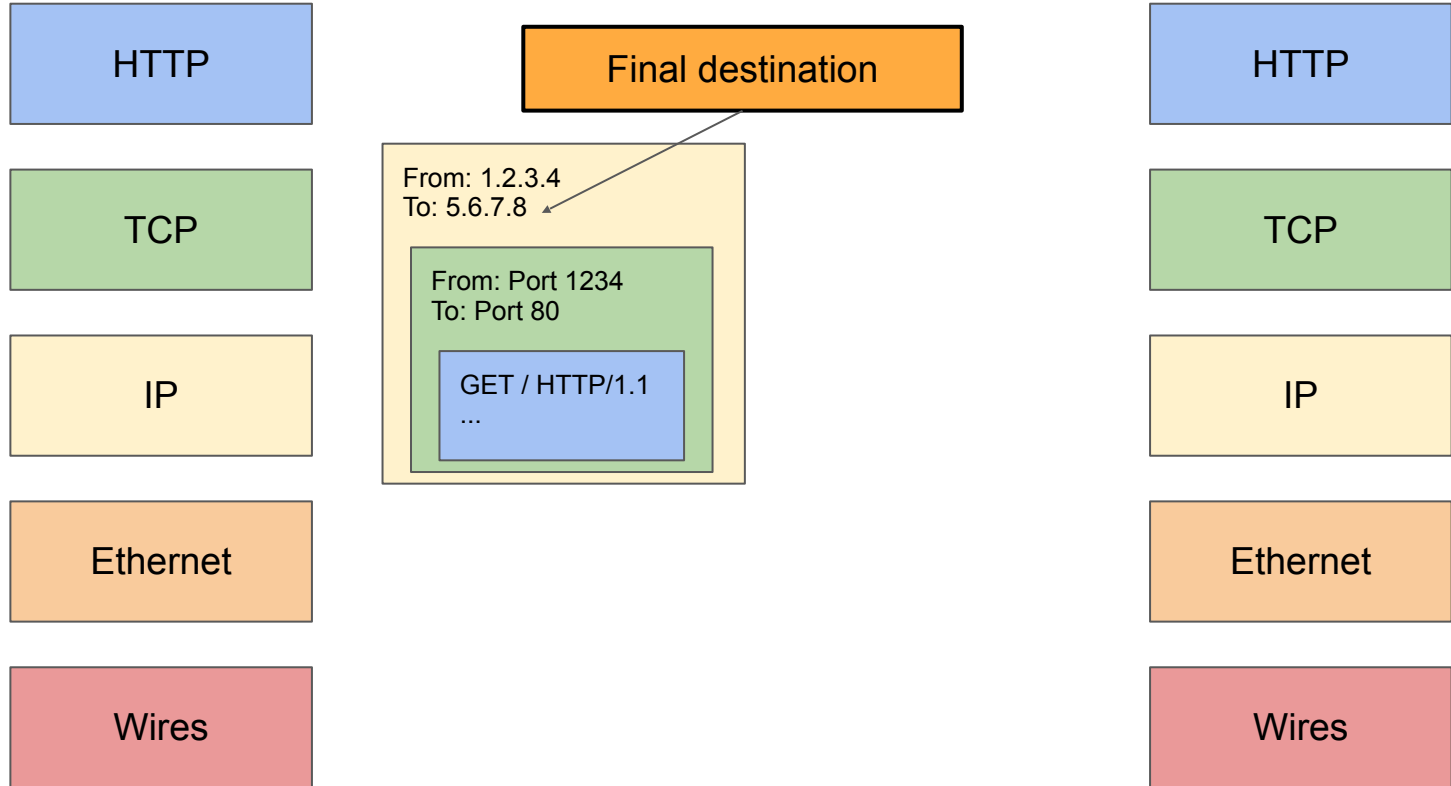

# Example: HTTP Request

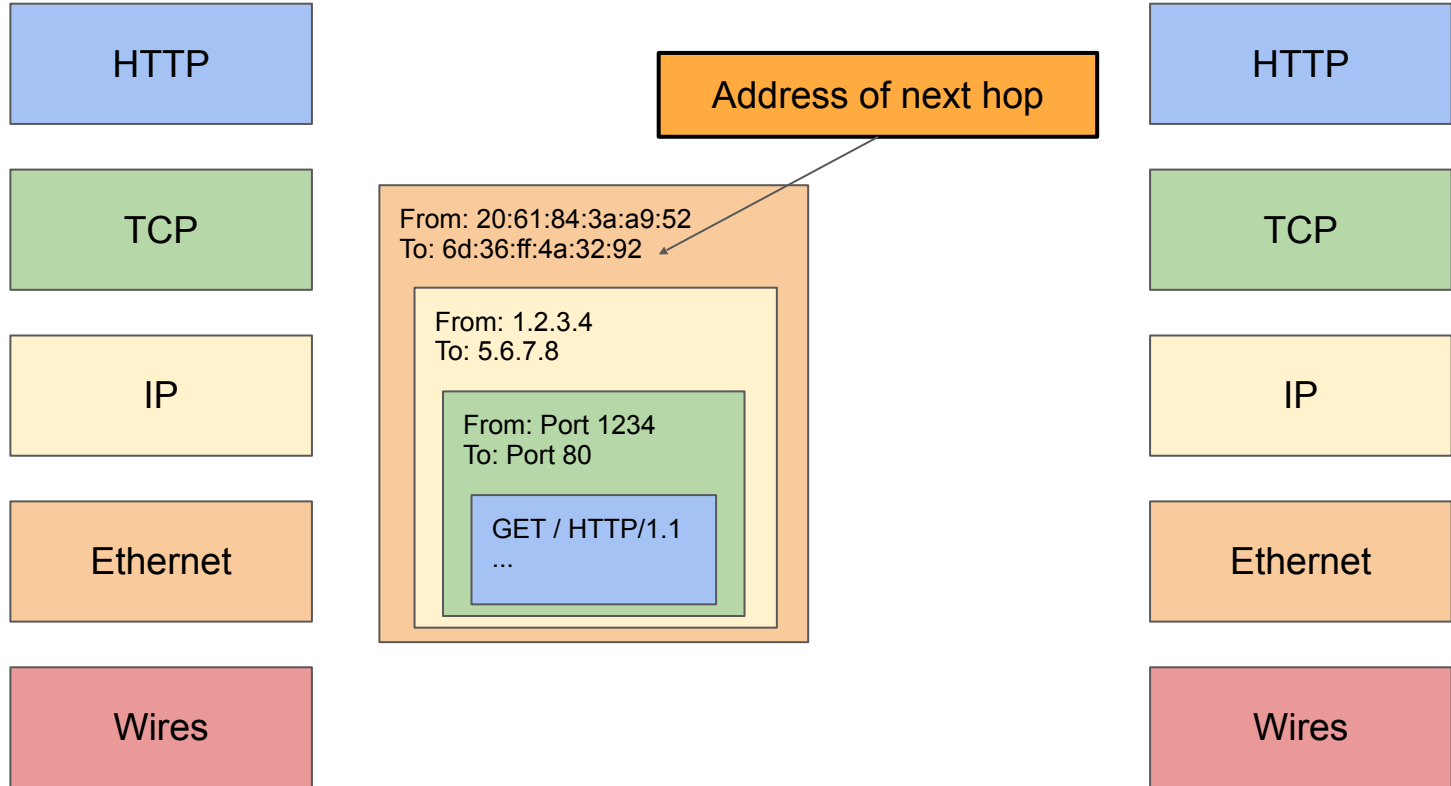

# Example: HTTP Request

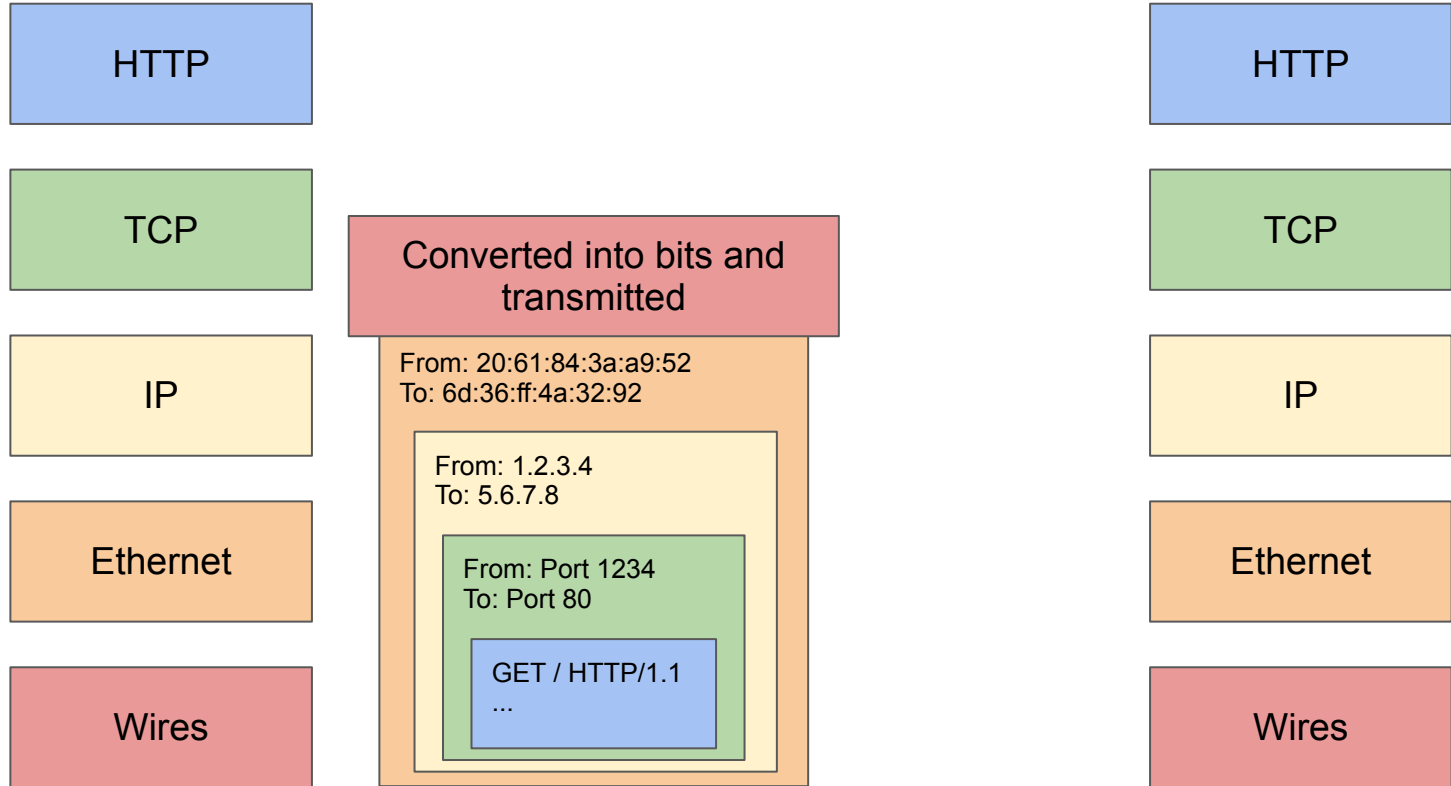

# Example: HTTP Request

HTTP

TCP

IP

Notice: The MAC addresses changed because the recipient is on a different network

Ethernet

Wires

Received over the physical medium

From: 89:8d:33:25:47:24  
To: d5:a9:20:68:e0:80

From: 1.2.3.4  
To: 5.6.7.8

From: Port 1234  
To: Port 80

GET / HTTP/1.1  
...

HTTP

TCP

IP

Ethernet

Wires

# Example: HTTP Request

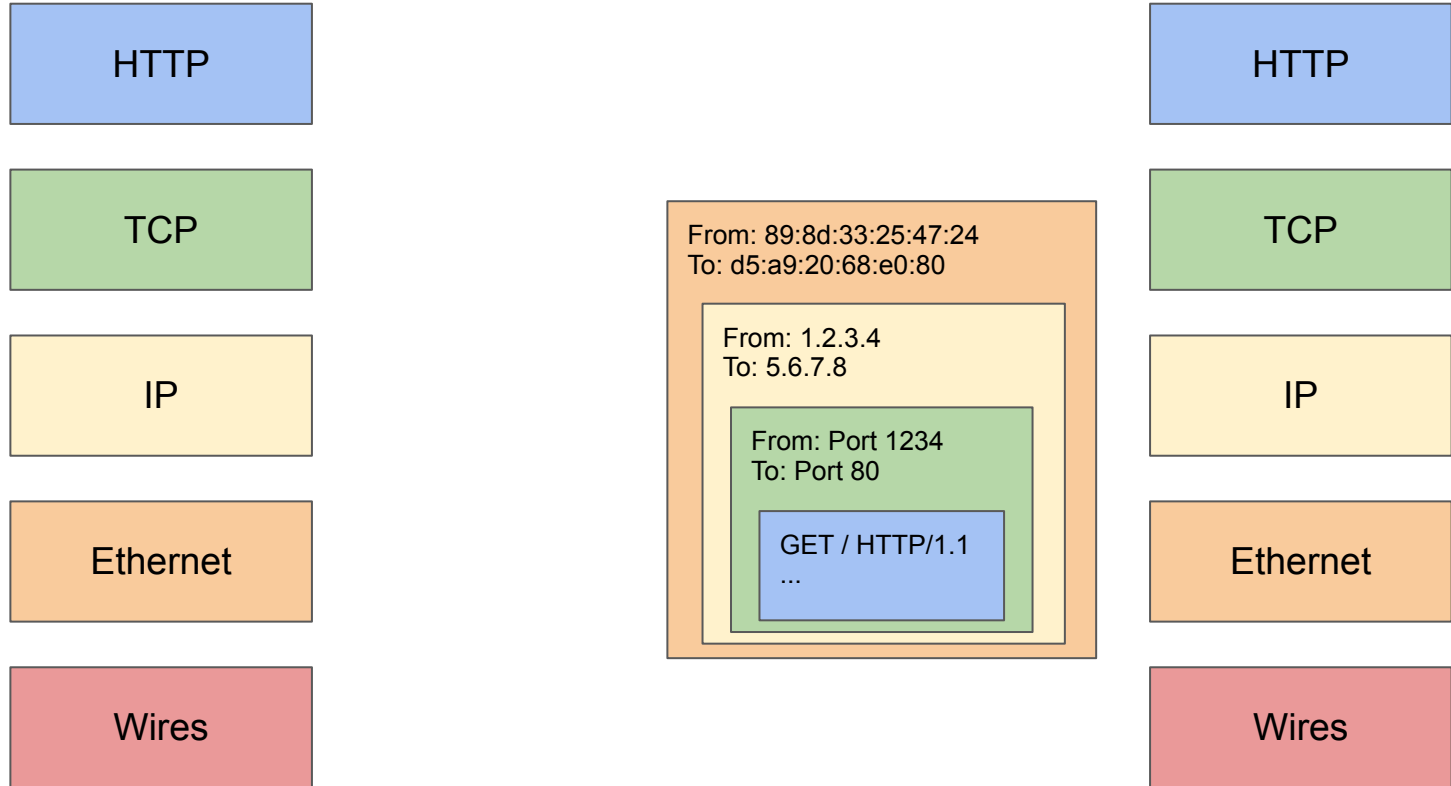

# Example: HTTP Request

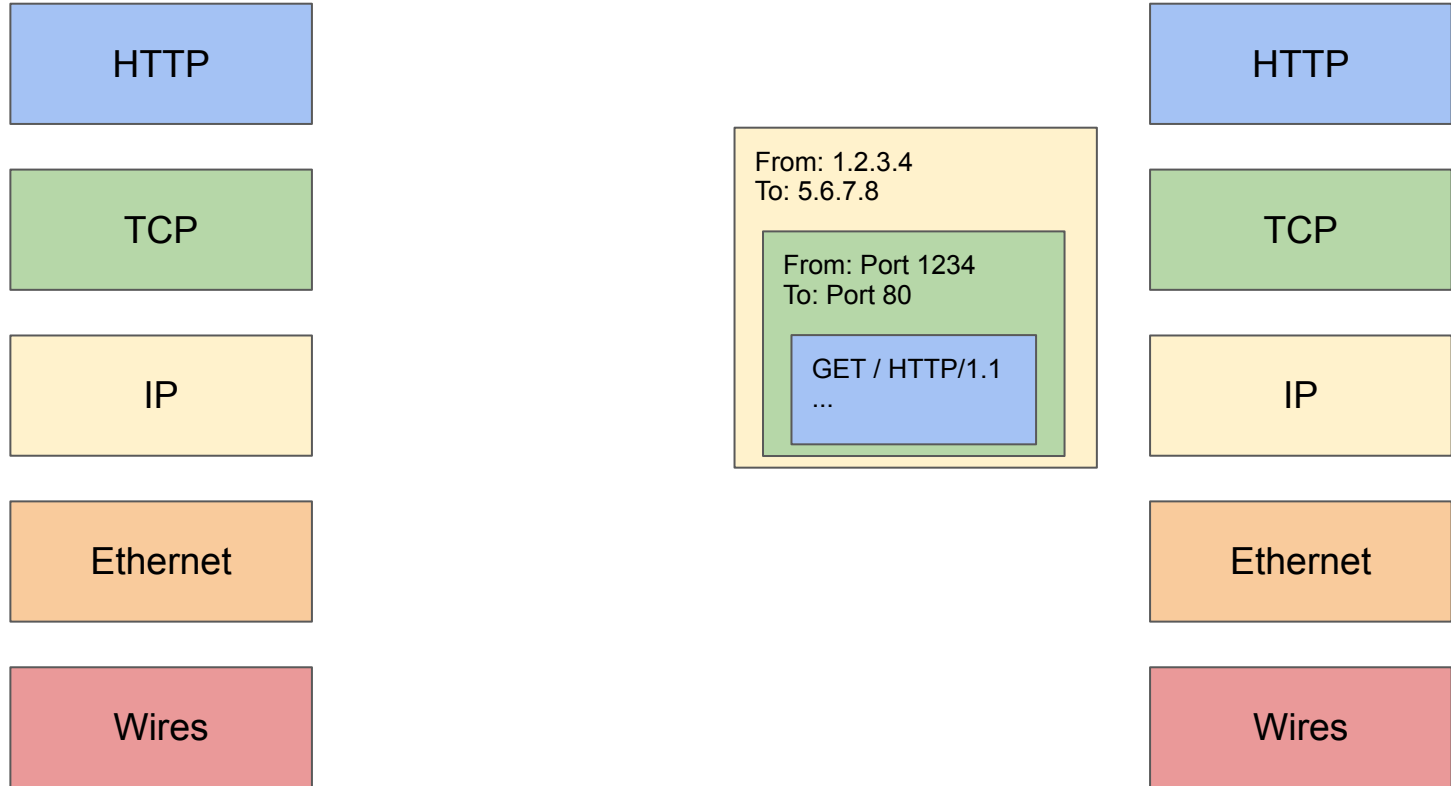

# Example: HTTP Request



# Example: HTTP Request

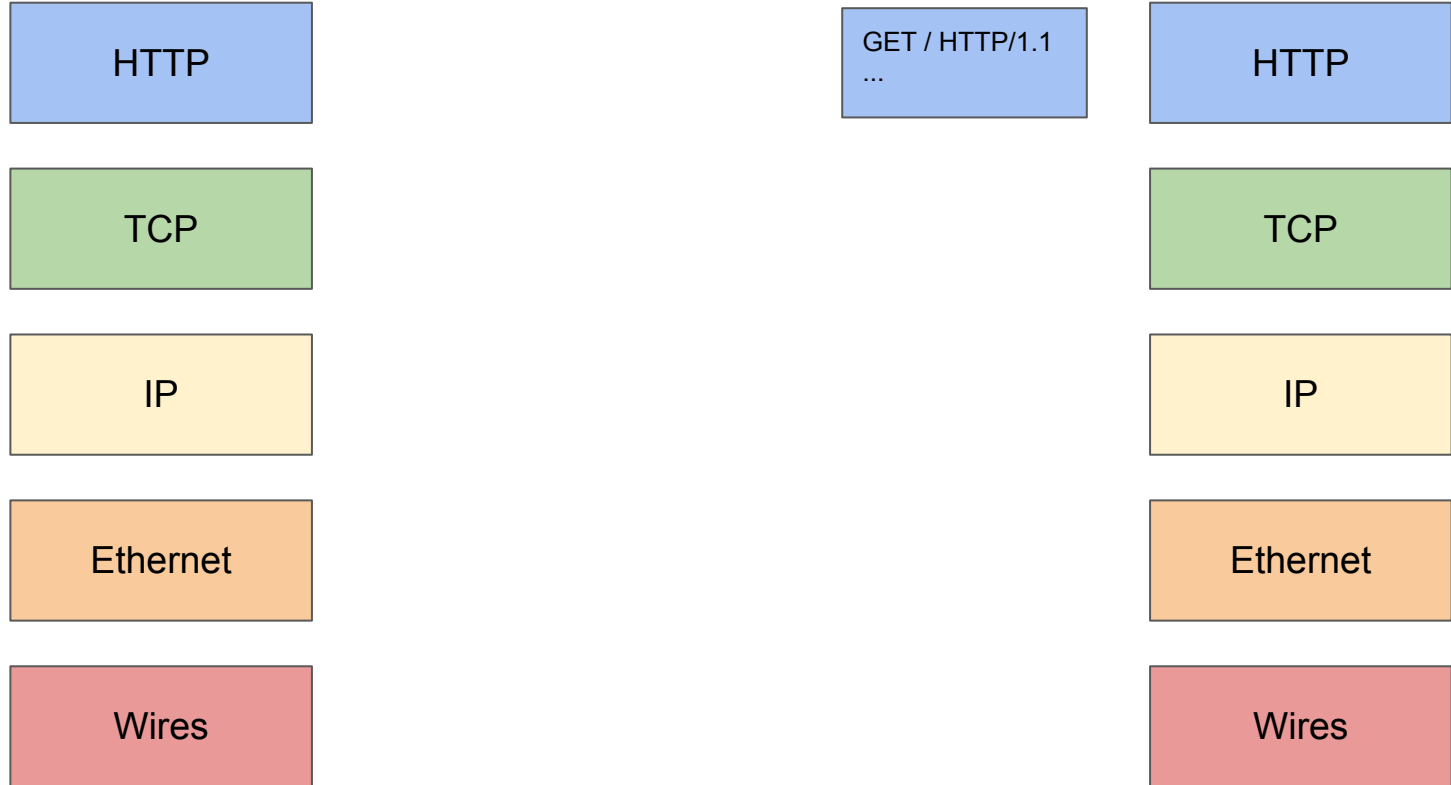

# Example: HTTP Request

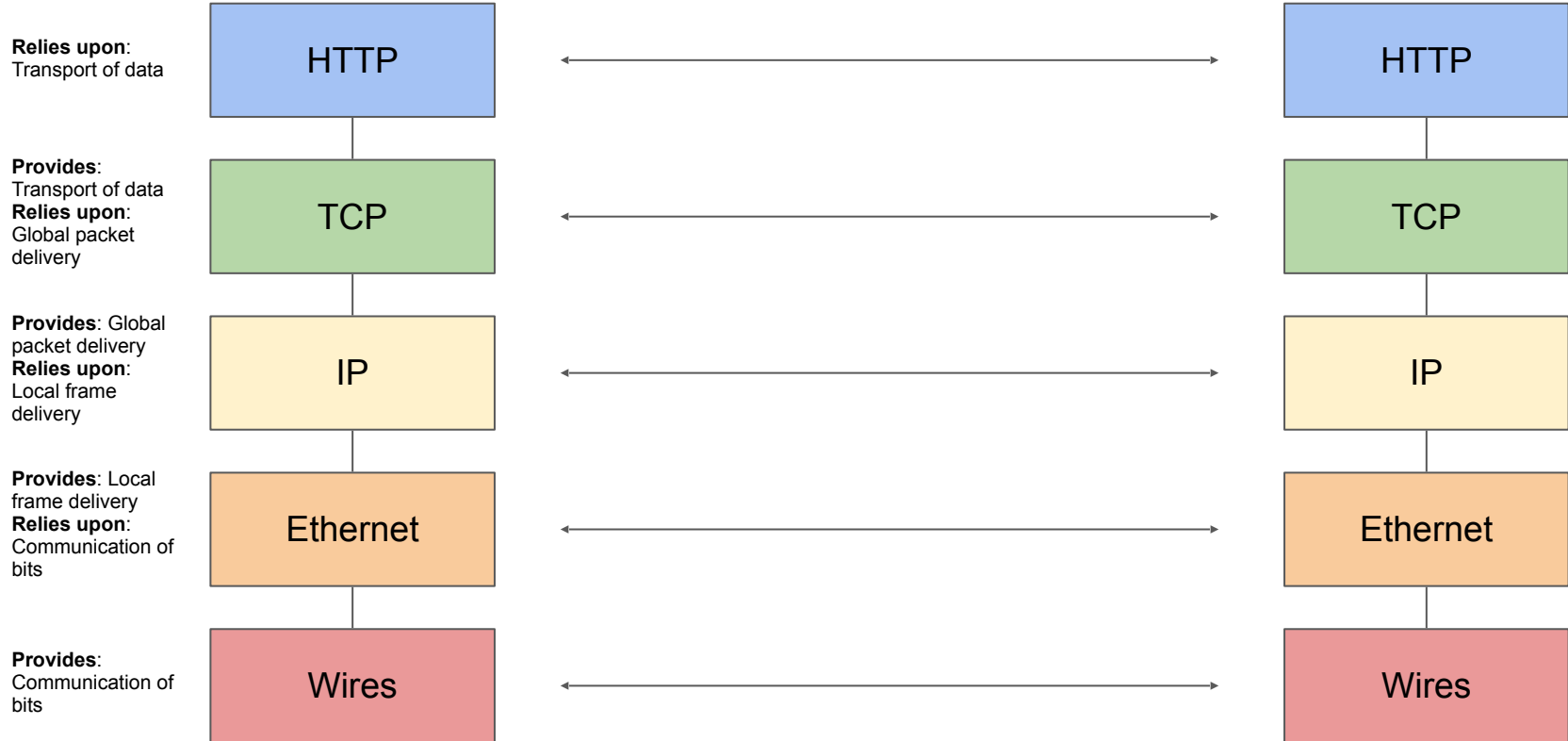

# Intro to Networking: Summary

- Internet: A global network of computers
  - Protocols: Agreed-upon systems of communication
- OSI model: A layered model of protocols
  - Layer 1: Communication of bits
  - Layer 2: Local frame delivery
    - Ethernet: The most common Layer 2 protocol
    - MAC addresses: 6-byte addressing system used by Ethernet
  - Layer 3: Global packet delivery
    - IP: The universal Layer 3 protocol
    - IP addresses: 4-byte (or 16-byte) addressing system used by IP
  - Layer 4: Transport of data (more on this next time)
  - Layer 7: Applications and services (the web)

